

LMC Series

Semi automatic L sealer packaging machine

PackagingSolutions



LMC Series

Semi automatic L sealer packaging machine



Technical Specifications

	LMC 58x44-M	LMC 80x65-M
Sealer Bar Opening: 250mm	Maximum Packaging Sizes (Width x Length x Height): 300 x 450 x 150mm	450 x 650 x 150mm
Maximum Capacity: 10 - 15 pack/min. *	Working Principle: Motorized	Motorized
Maximum Product Height: 150mm	L - Sealer Sizes: 580 x 440mm	800 x 650mm
Maximum Roll Diameter: Ø 250mm	Maximum Film Width: 550mm	700mm
Working Height: 860mm	Installed Power (50-60Hz): 400V, 10 A, Phase	400V, 10 A, Phase
Compr. Air Supply: No	Consumption (Maximum / Average): 2 kW / 1 kW	2 kW / 1 kW
Film Types: POF: 7-37 micron	Dimensions (AxBxC): 910 x 1525 x 1180mm	1145 x 2150 x 1300mm
PVC: 15-25 micro	Palletized Size (AxBxC): 1060 x 1675 x 1080mm	1300 x 2300 x 1210mm
Color: RAL7035	Weight (Net / Gross): 148 kg / 166 kg	201 kg / 226 kg

* Real working speed depends on the product dimensions and the film type.

Advantages:

- Practical semi-automatic solution for low and medium capacity requirements
- Easy to use, compatible with health and safety standards
- Ability to provide heat to wire at exact efficient dose, realized by I-Sealing System®
- Ability to keep wire temperature constant, realized by I-Sealing System®
- Increase in sealing quality, process accuracy and life-span by stabilized heat control

Features:

- M Series: Sealing L-Bar is driven by a motor (no need for compressed air)
- M Series: In automatic mode, sealing bar cycles automatically in predefined period
- M Series: In free mode, sealing bar is triggered by button
- M Series: Sensor detects any obstacle and stops the cycle automatically for safety
- H Series: Sealing L-Bar is closed by hand, weight is balanced with reverse load
- H Series: Magnetic holder keeps L-Bar closed for pre-defined time period
- Easy to integrate with all types of heat tunnel directly
- Products are discharged by internal belt conveyor automatically
- Operated by digital control panel
- Position of the working table can be adjusted with respect to product width
- Single-axis film roll holding profile can be easily removed, replaced and fixed
- Easily transportable on wheels inside a facility

Sealing:

- M Series: Sealing is actuated by motor in between wire and silicon rubber
- H Series: Sealing is actuated manually in between wire and silicon rubber
- Sealing wire is positioned on fixed bottom frame for safety
- Sealing wire is embedded into heat-resistant fiber profile
- Teflon belt covered silicon rubber increase sealing quality and life-span of silicon

Flexibility:

- Discharge belt height can be adjusted with respect to varying product height
- Discharge belt working time can be adjusted with respect to varying product length
- Power of sealing wire can be adjusted with respect to varying film thicknesses
- Heat, time and speed parameters can be easily adjusted via digital control panel
- Various language options are available in digital control panel
- Detailed technical menu is available in digital control panel

Optional:

- Automatic trim winder option is available upon request
- Stainless steel versions are available for wet/moist working environment
- Heat treated strong wooden case is available for risky transport conditions
- On-site installation and training service options are available

Quality:

- ISO9001 quality standards with the relevant norm's confirmation
- CE certifications, complies with the latest CE directives
- World-wide approved brands for all mechanical and electrical components
- 1 year warranty against manufacturing faults
- Wearable parts are not included in warranty terms
- 1 set of wear parts is provided along with the machine
- 5 years spare part stock availability is provided
- Installation, testing and training services are provided free of charge

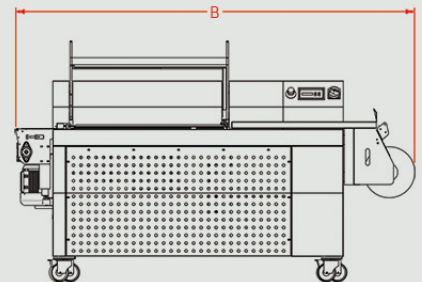
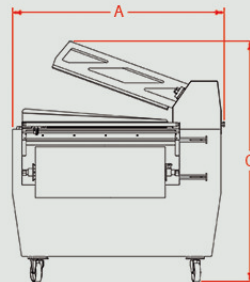
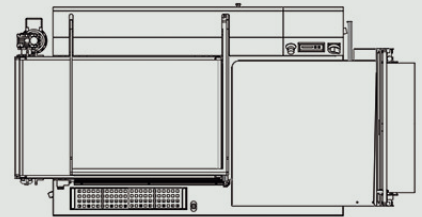
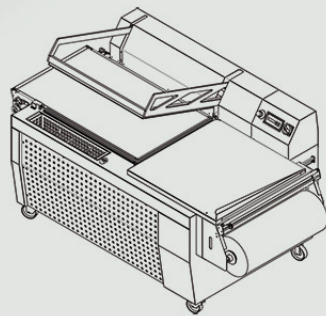

R2 EN