

IMPACT PRO 40 Series

Fully automated continuous sealer packaging machine

PackagingIntelligence



IMPACK PRO 40 Series

Fully automated continuous sealer packaging machine



Technical Specifications

Maximum Packaging Sizes (Width x Length x Height): 350 x Unlimited x 200mm	Conveyor Belt Width (D): 400mm	Air Consumption: No need*
Maximum Cycle: 60 cycle/min (example: DIN A4 form)	Maximum Roll Diameter: 300mm standard (adjustable)	Installed Power (50-60Hz): 400V, 6 Amper, 3 Faz
Maximum Conveyor Speed: 30 mt/min (adjustable)	Maximum Film Width: 650mm	Average Consumption: 6 kW / 3 kW
Sealer Bar Opening: 250mm	Film Types: 7-40 µm POF, PP, PE "V" Knife	Dimensions (WxLxH): 1510 x 2080 x 1895mm
Cross Sealer Length: 530mm	40-60 µm PE, OPP "W" Knife	Palletized Size (WxLxH): 1400 x 2270 x 1675mm
Working Height (E): 860mm	Color: Customised, (Mixed grey + RAL7015 + RAL7010)	Weight (Net / Gross): 780 kg / 860 kg

* Kissing Belt requires air. Air requirement: 6 Bar, Air Consumption: 1 liters / cycle

Advantages:

- Very compact and new esthetic 'Pro' design
- Continuous side sealer provides unlimited length packaging ability
- Very fast and flawless sealing property by Servo driven vertical sealer
- Easy to integrate with the production lines directly
- Recordable and re-callable package parameter settings

Features:

- Automatic length detection by sensor synchronized encoder control
- User-friendly color touch screen operator panel
- Automatic packaging film drive with tension control
- Automatic trim winder with tension control
- Feeding frequency control by sensor detection and PLC control

Sealing:

- Center-Seal property provides accurate and linear sealing line
- Adjustable precision and pressure on cutting and sealing force
- PID controlled sealing temperature inserted by touch panel
- Alternative sealing blade structures for various packaging material
- Product clearance control under seal bar by sensor

Flexibility:

- Easily adjustable wrt. varying product sizes and capacity
- Various language options and adaptable touch keyboard
- Memory Receipt property for prompt adjustments
- Perfect sealing blade design compatible with varying thicknesses

Optional:

- Solenoid actuator for side sealer: Free of compressed air requirement
- Printed film applicability by marker detection sensor and programming
- Center folder system for single layer flat film applicaiton
- Ability to control additional conveyors by inverters
- Linking Belt (compressed air is require*)

Quality:

- ISO9001 quality standards with the relevant norm's confirmation
- World-wide brands for all mechanical, electrical and pneumatic components
- CE certifications, complies with the latest CE directives
- One year warranty on non-wearable parts (extendable)
- Manufacturer's guarantee for spare part stock and after sales support
- Manufacturer's guarantee for spare part stock availability up to 5 years

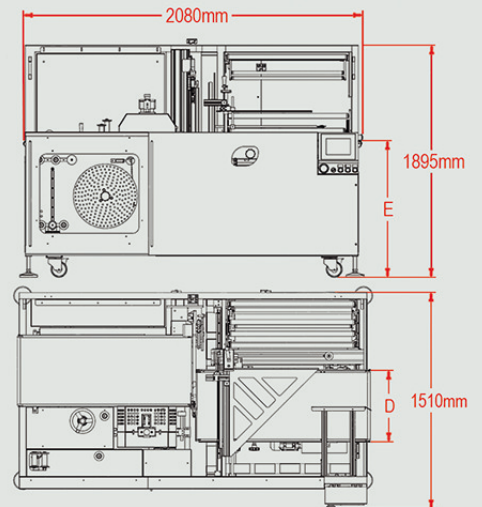
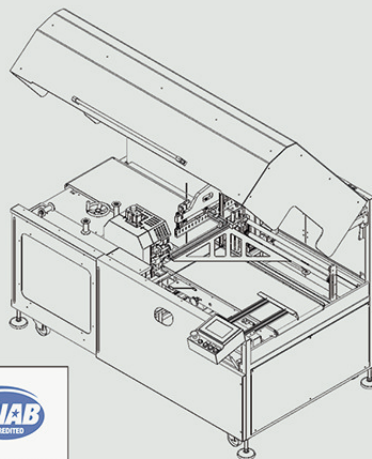

R6 EN

Serifali Mah. Serdivan Sk. 60 34775 Umraniye / Istanbul / TURKIYE
Phone: +90 216 365 8570 Fax: +90 216 365 5444
info@maripak.com www.maripak.com

Maripak®
Packaging & Industrial Equipment Inc.

IMPACT PRO 60-80-100 Series

Fully automated continuous sealer packaging machine

PackagingIntelligence



IMPACK PRO 60-80-100 Series

Fully automated continuous sealer packaging machine



Technical Specifications

	Impack 60 Pro	Impack 80 Pro	Impack 100 Pro
Sealer Bar Opening: 250mm	Max. Packaging Sizes (WxLxH): 550 x Unlimited x 200mm	750 x Unlimited x 200mm	950 x Unlimited x 200mm
Max. Conv. Speed: 30 mt/min (adjustable)	Min. Packaging Width: 150mm	200mm	400mm
Max. Cycle: 60 cycle/min (example: DIN A4 form)	Conveyor Belt Width (D): 600mm	800mm	1000mm
Max. Roll Diameter: 300mm standard (adjustable)	Max. Film Width: 800mm	950mm	1100mm
Working Height (E): 860mm	Installed Power (50-60Hz): 400V, 6 Ampere, 3 Phase	400V, 8 Ampere, 3 Phase	400V, 8 Ampere, 3 Phase
Air Consumption: No need*	Consumption (Max. / Average): 6 kW / 3 kW	7 kW / 4 kW	7 kW / 4 kW
Film Types: 7-40 µm POF, PP, PE * V * Knife	Dimensions (AxBxC): 1930 x 2640 x 2000mm	2230 x 2640 x 2000mm	2530 x 2640 x 2000mm
40-60 µm PE, OPP * W * Knife	Palletized Size (AxBxC): 2130 x 2955 x 1750mm	2430 x 2955 x 1750mm	2730 x 2955 x 1750mm
Color: Customised, (Mixed grey + RAL7015 + RAL7010)	Weight (Net / Gross): 1050 kg / 1170 kg	1410 kg / 1550 kg	1960 kg / 2180 kg

* Kissing Belt requires air. Air requirement: 6 Bar, Air Consumption: 1 liters / cycle

Advantages:

- Very compact and new esthetic 'Pro' design
- Continuous side sealer provides unlimited length packaging ability
- Very fast and flawless sealing property by Servo driven vertical sealer
- Easy to integrate with the production lines directly
- Recordable and re-callable package parameter settings

Features:

- Automatic length detection by sensor synchronized encoder control
- User-friendly color touch screen operator panel
- Automatic packaging film drive with tension control
- Automatic trim winder with tension control
- Feeding frequency control by sensor detection and PLC control

Sealing:

- Center-Seal property provides accurate and linear sealing line
- Adjustable precision and pressure on cutting and sealing force
- PID controlled sealing temperature inserted by touch panel
- Alternative sealing blade structures for various packaging material
- Product clearance control under seal bar by sensor

Flexibility:

- Easily adjustable wrt. varying product sizes and capacity
- Various language options and adaptable touch keyboard
- Memory Receipt property for prompt adjustments
- Perfect sealing blade design compatible with varying thicknesses

Optional:

- Solenoid actuator for side sealer: Free of compressed air requirement
- Printed film applicability by marker detection sensor and programming
- Center folder system for single layer flat film applicaiton
- Ability to control additional conveyors by inverters
- Linking Belt (compressed air is require*)

Quality:

- ISO9001 quality standards with the relevant norm's confirmation
- World-wide brands for all mechanical, electrical and pneumatic components
- CE certifications, complies with the latest CE directives
- One year warranty on non-wearable parts (extendable)
- Manufacturer's guarantee for spare part stock and after sales support
- Manufacturer's guarantee for spare part stock availability up to 5 years

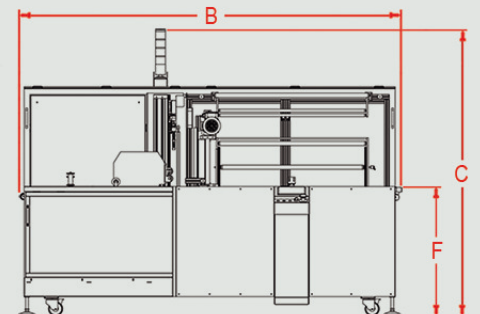
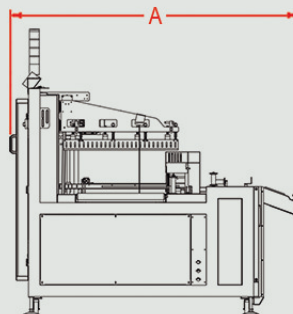
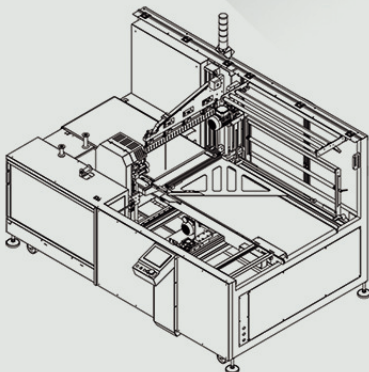
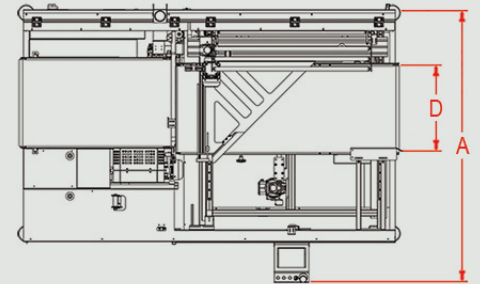

R2 EN